

DEISA overview: project status, strategies and perspectives

Towards cooperative extreme computing in Europe

Victor Alessandrini
IDRIS - CNRS
va@idris.fr



Table of contents

- **1 - Project Objectives**
- **2 - Infrastructure overview**
- **3 - Global strategies**
- **4 - Infrastructure organization**
- **5 - Running the infrastructure: services**
- **6 - Running the infrastructure: applications**
- **7 - Prospective issues.**
- **8 - Conclusions**

1 - DEISA objectives

- *To enable Europe's terascale science by the integration of Europe's most powerful supercomputing systems.*
- *Enabling scientific discovery across a broad spectrum of science and technology is the only criterion for success*
- DEISA is an European Supercomputing Service built on top of existing national services. This service is based on the deployment and operation of a persistent, production quality, distributed supercomputing environment with continental scope.
- The integration of national facilities and services, together with innovative operational models, is expected to add substantial value to existing infrastructures.
- Main focus is High Performance Computing (HPC).

2 – Infrastructure overview

- Description of the hardware infrastructure

DEISA Sites



BSC	<i>Barcelona Supercomputing Centre</i>	Spain
CINECA	<i>Consorzio Interuniversitario per il Calcolo Automatico</i>	Italy
CSC	<i>Finnish Information Technology Centre for Science</i>	Finland
EPCCC/HPCx	<i>University of Edinburgh and CCLRC</i>	UK
ECMWF	<i>European Centre for Medium-Range Weather Forecast</i>	UK (int)
FZJ	<i>Research Centre Juelich</i>	Germany
HLRS	<i>High Performance Computing Centre Stuttgart</i>	Germany
IDRIS	<i>Institut du Développement et des Ressources en Informatique Scientifique - CNRS</i>	France
LRZ	<i>Leibniz Rechenzentrum Munich</i>	Germany
RZG	<i>Rechenzentrum Garching of the Max Planck Society</i>	Germany
SARA	<i>Dutch National High Performance Computing and Networking centre</i>	The Netherlands

THE DEISA SUPERCOMPUTING GRID



**AIX distributed
super-cluster**



**Vector systems
(NEC, ...)**



**Linux systems
(SGI, IBM, ...)**

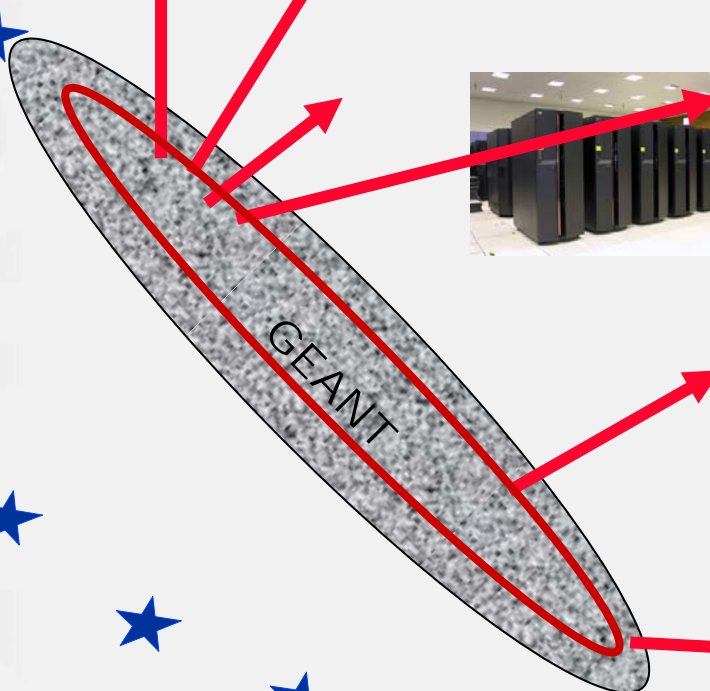

The DEISA supercomputing environment

(21.900 processors and 145 Tf in 2006, more than 190 Tf in 2007)

- IBM AIX Super-cluster
 - FZJ-Julich, 1312 processors, **8,9 teraflops peak**
 - RZG – Garching, 748 processors, **3,8 teraflops peak**
 - IDRIS, 1024 processors, **6.7 teraflops peak**
 - CINECA, 512 processors, **2,6 teraflops peak**
 - CSC, 512 processors, **2,6 teraflops peak**
 - ECMWF, 2 systems of 2276 processors each, **33 teraflops peak**
 - HPCx, 1536 processors, **11 teraflops peak**
- BSC, IBM PowerPC Linux system (MareNostrum) 4864 processeurs, **40 teraflops peak**
- SARA, SGI ALTIX Linux system, 416 processors, **2,2 teraflops peak**
- LRZ, Linux cluster (2.7 teraflops) moving to SGI ALTIX system (5120 processors and **33 teraflops peak in 2006, 70 teraflops peak in 2007**)
- HLRS, NEC SX8 vector system, 576 processors, **12,7 teraflops peak.**
- **Systems interconnected with dedicated 1Gb/s network – currently upgrading to 10 Gb/s – provided by GEANT and NRENs**

3 – Global strategies

- **General ideas about the DEISA computing strategies and its positioning in the European computational ecosystem.**

3a - Strategic vision

- DEISA is based on a **deep integration and tightly coupled operation** of high end computational resources, rather than a loose federation model.
- **Scientific impact (enabling new science) is the only criterion for success.**
- **Integration of IT systems is mainly a strategic issue. Technology choices follow from the business and operational models of virtual organizations.**
- **This is why DEISA puts forward an innovative vision for the integration of high end computing systems: promoting cluster software (global file systems, batch managers) to distributed super-cluster middleware (distributed global file systems, multi-cluster batch managers).**
- **DEISA technology choices are fully open. DEISA is not tied to any specific pre-established technology.**

3b - The technology cycle

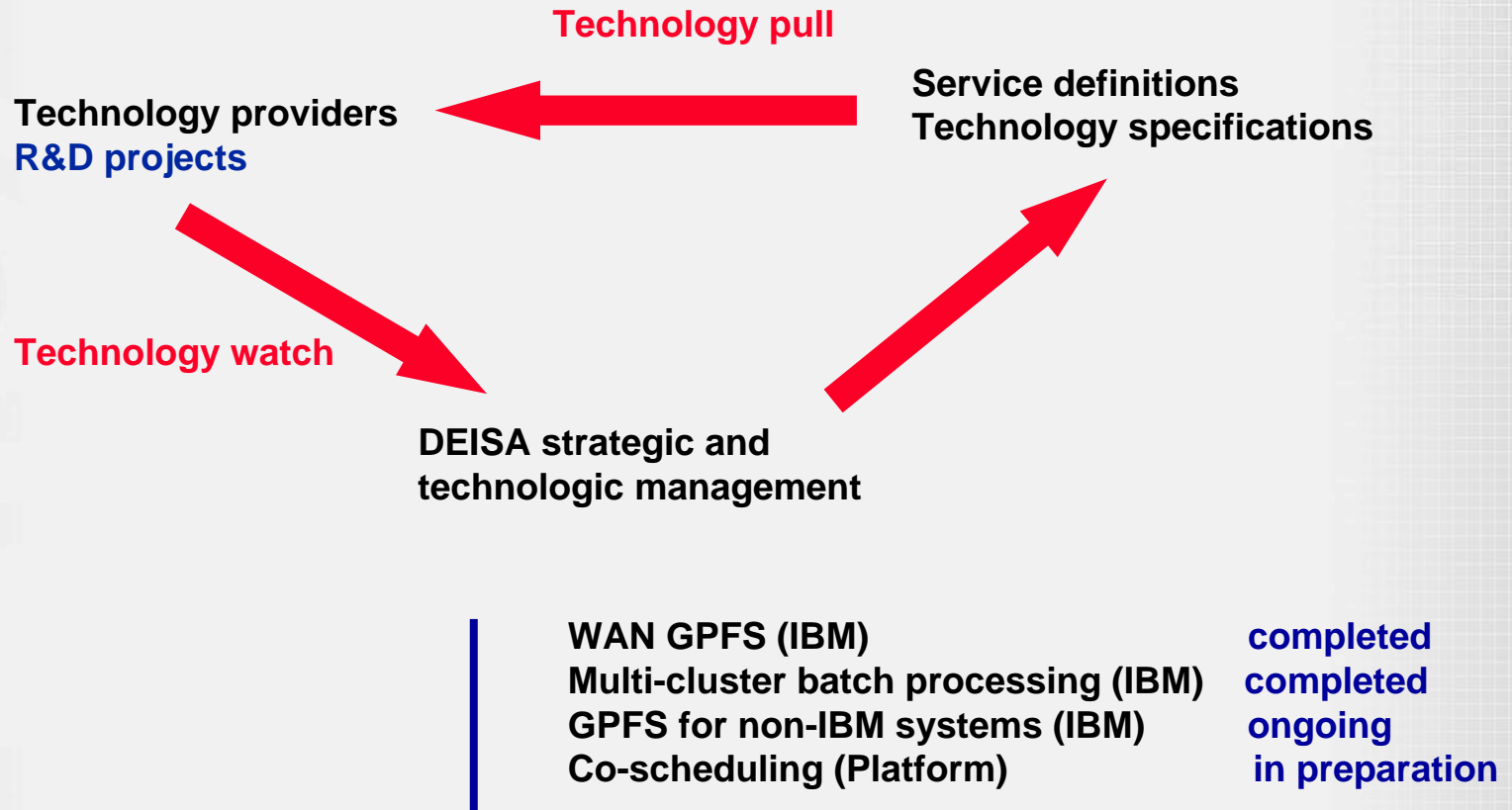

3c - Basic requirements for the DEISA research Infrastructure

- **Fast deployment of a persistent, production quality, grid empowered supercomputing infrastructure with continental scope.**
- **The European supercomputing service built on top of existing national services requires reliability and non disruptive behavior.**
- **User transparency : users should not be disturbed by technology overhead. Grid technologies should work seamlessly in the background.**
- **Application transparency : applications are part of the corporate wealth of virtual organizations, and they should be portable and independent (as much as possible) of the underlying Grid technologies.**
- **Top-bottom approach: technology choices follow from the business and operational models of our virtual organization. DEISA technology choices are pragmatic and fully open. There is practically no « DEISA specific middleware ».**
- **Focus on HPC**

3d - About HPC

- **Dealing with large complex systems** requiring exceptional computational resources. For algorithmic reasons, required resources grow much, much faster than the systems size and complexity.
- **Dealing with huge, datasets, involving large files.** Typical datasets in SC centres are of the order of several PBytes. Datasets are active (not just archiving, reads are almost as frequent as writes)
- **Little usage of commercial or public domain packages.** Most applications are virtual organization corporate codes incorporating specialized know how (to make a difference in the international competition). This is why specialized user support is so important.
- **Codes are fine tuned and targeted for a relatively small number of well identified computing platforms.** They are extremely sensitive to the production environment.
- For **any** kind of data movement, transit time is $T = L + (\text{Packet size})/B$, where **L** is latency and **B** is bandwidth.
- **The main requirement for high performance is bandwidth** (from processor to memory, from processor to processor, from node to node, from system to system). Internal optimization of communications - high bandwidth and specialized tricks to hide latencies - are the main differences between supercomputers and clusters.

3e - HPC and Grid computing

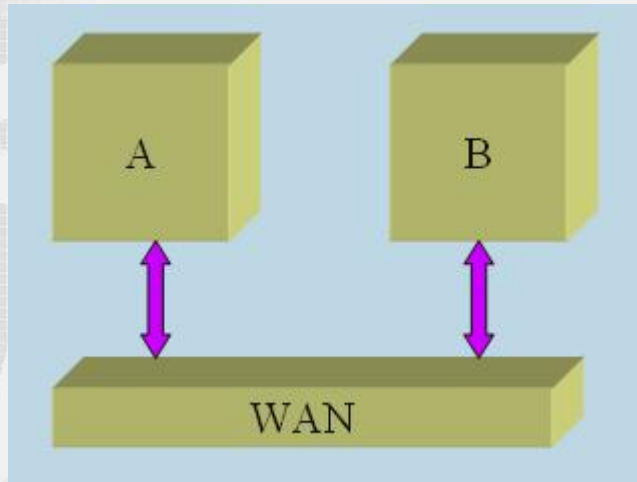

Problem: the speed of light is not big enough

Finite signal propagation speed boosts message passing latencies in a WAN from a **few microseconds** to **tens of milliseconds** (if A is in Paris and B in Helsinki)

If A and B are two halves of a tightly coupled complex system, communications are frequent and the enhanced latencies will kill performance.

Grid computing works best for embarrassingly parallel applications, or coupled software modules with limited communications.

Example: A is an ocean code, and B an atmospheric code. There is no bulk interaction. Systems interact only at the ocean-atmosphere boundary, with limited communications.

Large, tightly coupled parallel applications should be run in a single platform. This is why we still need high end supercomputers.

DEISA implements this requirement by rerouting jobs and balancing the computational workload at a European scale.

3f - How is DEISA enhancing HPC services in Europe?

- **Running larger parallel applications** in individual sites, by a cooperative reorganization of the global computational workload on the whole infrastructure, or by the operation of the **job migration service** inside the AIX super-cluster.
- Enabling **workflow applications** with UNICORE (complex applications that are pipelined over several computing platforms)
- Enabling coupled multiphysics Grid applications (when it makes sense)
- Providing a **global data management** service whose primordial objectives are:
 - Integrating distributed data with distributed computing platforms
 - **Enabling efficient, high performance access to remote datasets** (with Global File Systems and stripped GridFTP). We believe that this service is critical for the operation of (possible) future European petascale systems
 - Integrating hierarchical storage management and databases in the supercomputing Grid.
- **Deploying portals** as a way to hide complex environments to new users communities, and to interoperate with another existing grid infrastructures.

4 – Infrastructure organization

- **Description of the project organization and roadmap**

4a - Project organization

- *System Integration, deployment and operation of the infrastructure:*
 - SA1 : Networking
 - SA2 : Global File Systems
 - SA3 + eSA3: Middleware and Ressource Management
 - SA4 : User Support
 - eSA4: Applications Enabling and Benchmarking
 - SA5: Security
 - eSA2: Operations
 - eSA4: Applications Enabling and Benchmarking
 - JRA7: Heterogeneous resource management (JRA7)
- *Applications*
 - Scientific JRAs (JRA1 to JRA6)
 - The Applications Task Force
 - The DEISA Extreme Computing Initiative

4b - Planned project roadmap

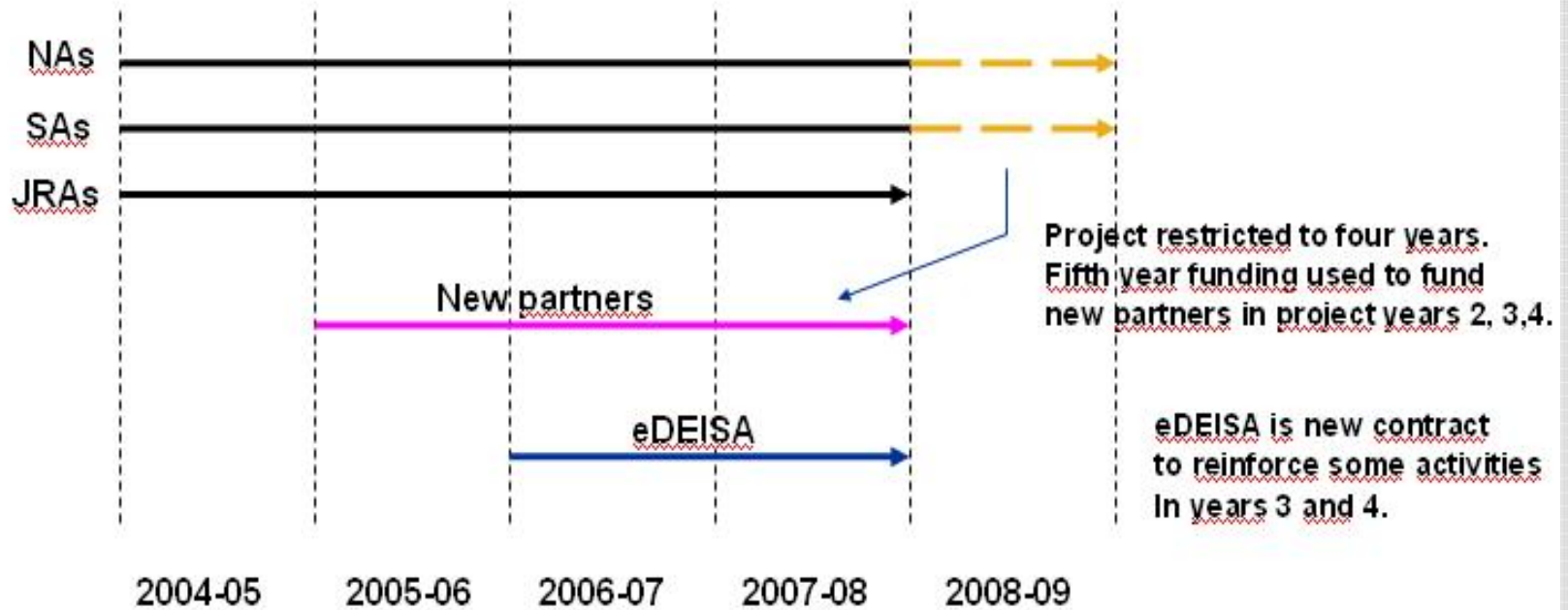

4c - Extending the initial DEISA Infrastructure (eDEISA)

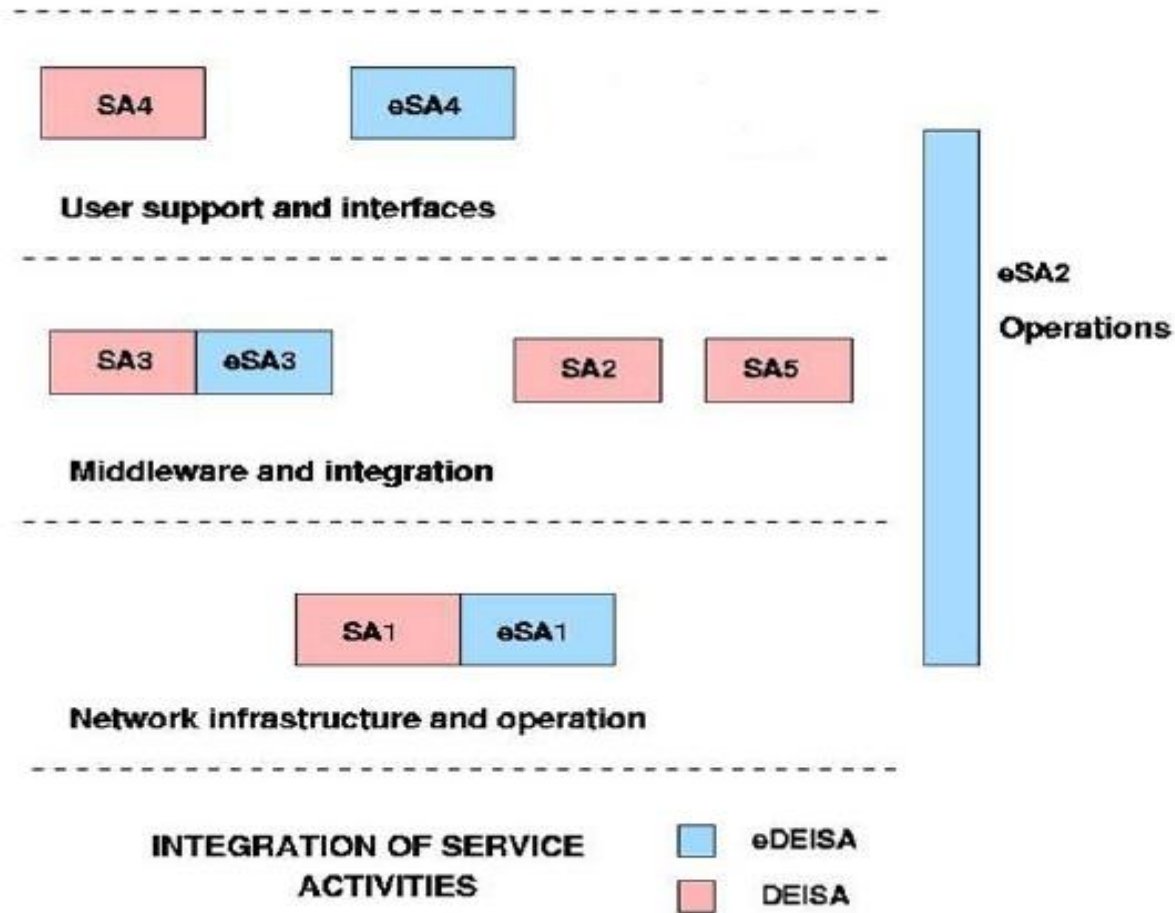

5 – Running the infrastructure: services

- **Description of the basic DEISA supercomputing services:**
 - **UNICORE**
 - **Global File Systems**
 - **Job Migration**
 - **Co-scheduling**
 - **Fast file transfer**
 - **Common production Environment**

5a: Workflow simulations using UNICORE

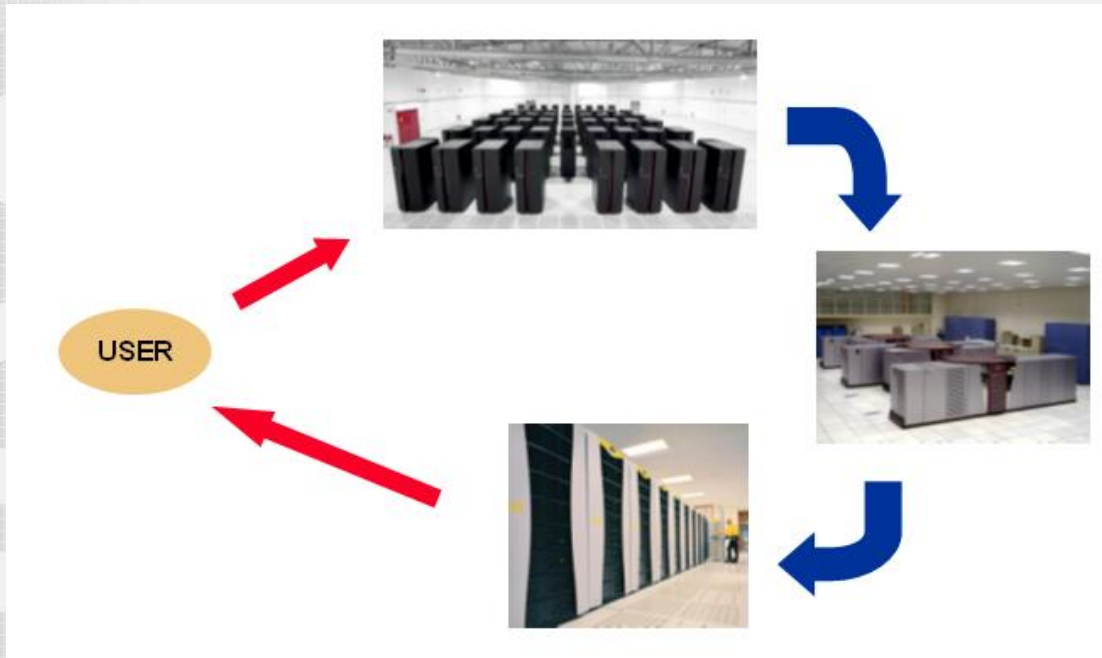

UNICORE supports complex simulations that are pipelined over several heterogeneous platforms (workflows).

UNICORE handles workflows as a unique job and transparently moves the output – input data along the pipeline.

UNICORE clients that monitor the application can run in laptops.

UNICORE has a user friendly graphical interface. DEISA has developed a command line interface for UNICORE.

**UNICORE infrastructure including all sites has full production status.
It has proven to be very stable during the last few months.**

5b : Global File Systems

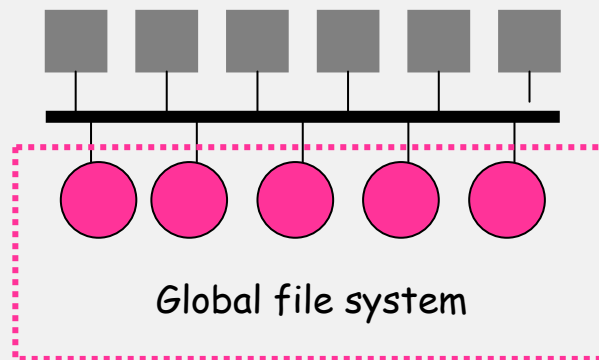

Sophisticated software environment, necessary to provide single system image if a clustered computing platform.

They provide global data management. Data in the GFS is “symmetric” with respect to all computing nodes.

GFS encapsulate sophisticated distributed computing and Grid technologies. Applications do not need to be modified to benefit from GFS services.

IBM GPFS is a Global File System **that can be deployed over a WAN** (distributed cluster). Users see remote files as if they were local files.

The “P” (for parallel) allows GPFS to use multiple TCP streams to move large chunks of data, using the full network bandwidth. This enables high performance access to remote data.

5b - DEISA Global File System integration in 2006

(based on IBM's GPFS)

AIX IBM domain



Linux SGI

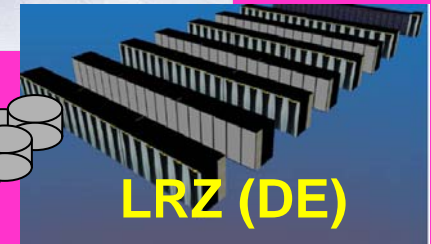

High Performance Common Global File System
various architectures / operating systems
High bandwidth (up to 10 Gbit/s)



LINUX Power-PC

5b – Global File System usages

- Basic usage is **DATA SHARING**: data placed in DEISA GPFS can be accessed with comparable (high) performance from any computing platform. This enables the deployment of cooperative working environments for trans-national scientific collaborations.
- DEISA uses GPFS to enable a **JOB MIGRATION** service inside the AIX super-cluster. If a user places code and data in DEISA GPFS and selects the Common Production Environment, then the multi-cluster function in Load leveler allows the transparent migration of the job to another similar computing platform.
- GPFS is essentially a very efficient network file system. Remote file systems are mounted on local file systems without performance penalty. I/O performance is mainly controlled by local file system performance.
- Remote files appear as local files to the user, but remote the data is implicitly moved to the local system. GPFS can be used to efficiently move huge data sets across computing platforms

Global File System Interoperability demo during Supercomputing Conference 2005 in Seattle

American and European supercomputing infrastructures linked:
bridging communities with scalable, wide-area global file systems

TeraGrid Sites



DEISA Sites



5c - Other basic services

- **Job migration inside the AIX super-cluster.** Based on LoadLeveler Multi-Cluster, it allows system administrators to reroute jobs to other sites, in a way transparent for the end users. Used to move away simple jobs of « implicit users » to make place for a bigger application in a site. **Full production status.**
- **Co-allocation.** We are starting to prepare a first generation co-allocation service on the full heterogeneous infrastructure, using LSF Multi-cluster. Important for coupled Grid applications and for data movement. **Service in development phase, prototype expected in 6-9 months**
- **Remote I/O and fast data transfers with GridFTP.** See next transparency
- **Integrating hierarchical data management and databases in the supercomputing Grid.** **In progress**
- **Deploying and monitoring a Common Production Environment.** **Operational over the whole infrastructure.**

5d - Accessing remote data: high performance remote I/O and file transfer

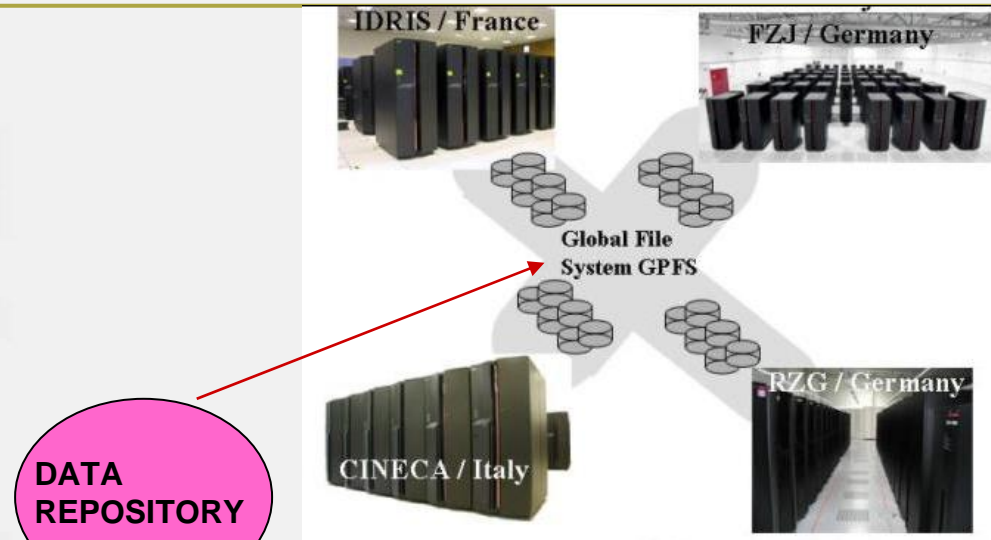

Remote I/O with global file systems **implicitly** moves data across platforms (in production today)

DEISA will also deploy **explicit** high performance data movers, using a parallel implementation of GridFTP



GridFTP



Co-scheduled, parallel data mover tasks

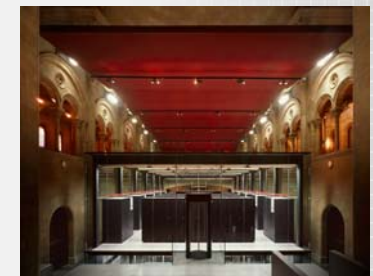

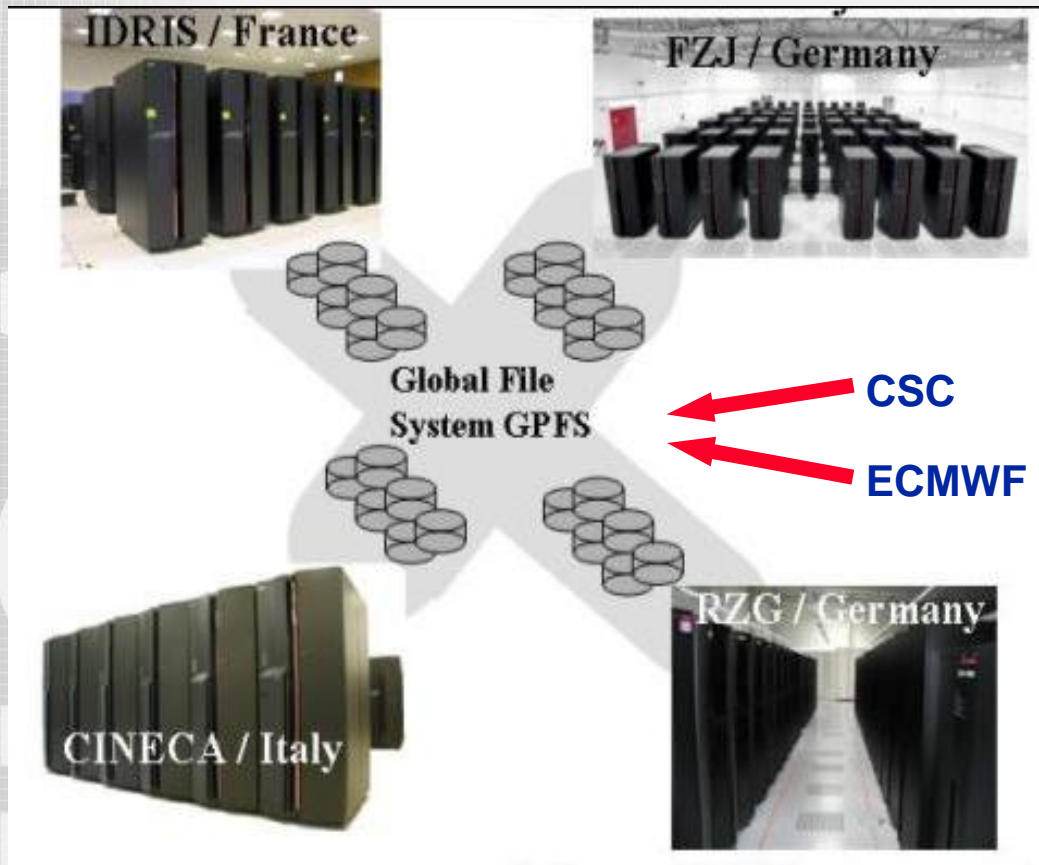

Services:

High performance datagrid via GPFS
Access to remote files use the full available network bandwidth

Job migration across sites
Used to load balance the global workflow when a huge partition is allocated to a DEISA project in one site

Common Production Environment

Full production status of dedicated 1 Gb/s network
GPFS : Full production at IDRIS, RZG, FZJ, CINECA, CSC, ECMWF
JOB MIGRATION: Full production in core sites

5e: AIX super-cluster operational model

- DEISA provides an **integrated supercomputing environment, with efficient data sharing through high performance global file systems**. This is highly transparent to end users.
- DEISA enables **job migration across sites** (also transparent to end users). Exceptional resources for very demanding applications are made available by the operation of the global resource pool. **We are load balancing computational workload at a European scale**.
- Huge, demanding applications can be run “as such”.
- Support of Grid applications (which are distributed by design).
- With this operational model, the DEISA super-cluster is not very different from a “true” monolithic European supercomputer (which must be partitioned in any case for fault tolerance and QoS).
- *The main difference comes from the coexistence of several independent administration domains*. This requires, as in TeraGrid, coordinated production environments.

6 . Running the Infrastructure: applications

- **Actions to enable leading computational science in Europe**
 - Initial program: a number of Joint Research Activities integrated in the project from the start.
 - Moving towards « exceptional users » : the DEISA Extreme Computing Initiative launched in 2005.
 - The DEISA Life Sciences Portal (planned)

6a - Scientific JRAs

	IDRIS	RZG	EPCC	CINECA	CRI (Fiat)	BSC	HLRS	Activity
JRA1		X					X	Enabling applications in Materials Sciences
JRA2			X					Deploying a complex computational environment for Cosmology applications
JRA3		X						Enabling one complex application in Plasma Physics
JRA4	X					X		Life sciences: several leading genomic applications
JRA5				X	X			Computational Fluid Dynamics in the automobile industry
JRA6	X						X	<u>Coupled applications: Astrophysics, Environment, Combustion.</u>

JRA1 – Materials Sciences



Alexandria - Mozilla Firefox

File Edit View Go Bookmarks Tools Help

DEISA
DISTRIBUTED EUROPEAN INFRASTRUCTURE FOR SUPERCOMPUTING APPLICATIONS

Alexandria
JRA1 & JRA3 Applications' Portal

Home | Science Areas | SA Components | Tools | Links | Contact | Help

Welcome

to the DEISA's Application Portal of the Joint Research Activities (JRAs) 1 and 3

- **Material Sciences (JRA1)**
Physical, chemical, and biological processes for many problems in computational physics, biology, and materials sciences span length and time scales of many orders of magnitude. For example, on the microscopic level, the typical bond distance between atoms is of the order of Angstroms (the lattice constant). More ...
- **Plasma Physics (JRA3)**
Research on magnetic confinement fusion has undergone large changes during the last decade, moving away from the semi-empirical, predominantly experiment-driven approach to one accompanied and supported in all areas by first-principle based modelling. This development has been particularly dramatic in the area of turbulence. More ...

General DEISA news

JRA 1 & JRA3 Applications' Portal available
Wed., 25 Jan 2006 14:00:00 CET
Starting Feb 01, DEISA's JRA1 and JRA3 will become available to the all DEISA extreme computing initiative users. Use the link to register for portal use. (active Feb 01) More ...

JRA 1 & JRA3 publish news feed on their Applications' Portal.
Tue., 24 Jan 2006 11:06:42 CET
Starting Feb 01, DEISA's JRA1 and JRA3 publish a news feed using the RSS technology. More ...

Portal v1.08 hosted by RZG - Max Planck Gesellschaft powered by Cocoon

Full support of the CPMD application within DEISA

NEC SX-8 CPMD optimization

Support of QUICKSTEP code in DEISA

Implementation of a portal for Materials Sciences and Plasma physics

JRA2 – Cosmology: objectives

- to avail the Virgo Consortium of the most advanced features of Grid computing by porting their production applications
 - GADGET and FLASH
- to make an effective use of the DEISA infrastructure
- to lay the foundations of a Theoretical Virtual Observatory (VirtU).
 - JRA2 funded 50/50 by DEISA and VirtU
- EPCC works in close partnership with the Virgo Consortium
 - JRA2 managed jointly by Dr Gavin Pringle (EPCC/DEISA) and Prof. Carlos Frenk (co-PI of both Virgo and VirtU)
 - work progressed after gathering clear user requirements from Virgo Consortium.
 - requirements and results published as public DEISA deliverables.

TORB code (turbulent transport in plasmas) related activities

A trans-national European collaboration for developing the TORB code for stellarator configurations has been established between CIEMAT, Spain and IPP, Germany.

After the TORB code was ported to the MareNostrum supercomputer of BSC, simulations were continued at BSC.

The results have been presented at the IAEA Technical Meeting on Inno-vative Concepts and Theory of Stellarators, Madrid, October 10-11, 2005.

For the DEISA-TeraGrid interoperability demonstration during the Supercomputing Conference 2005 in Seattle, TORB was a featured DEISA application

Paper :

R. Hatzky: Domain Cloning for a Particle-in-Cell (PIC) Code on a Cluster of Symmetric-Multiprocessor (SMP) Computers, Parallel Computing, in press

Finalizing work on TORB code

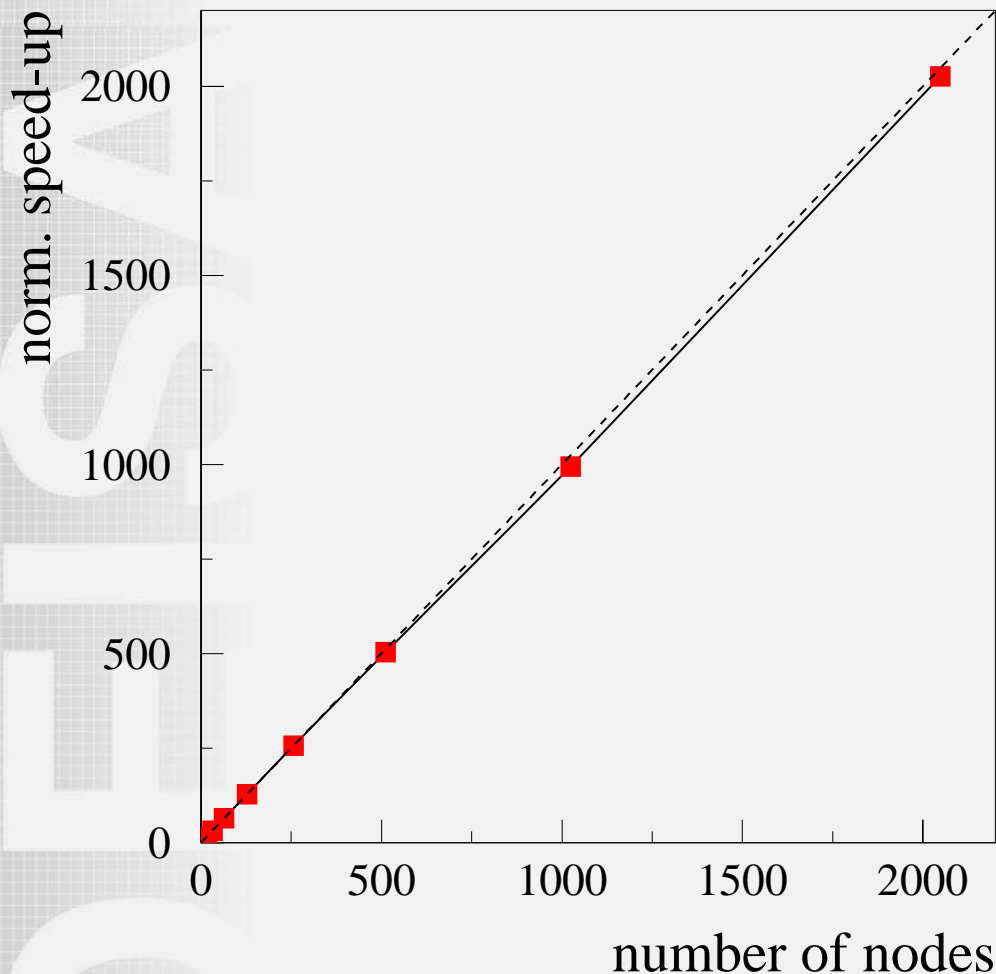

TORB Hyperscalability on MaresNostrum at BSC

Result with 4096 processors:

Speed-up = 4000

Parallel efficiency = 99%

Sustained

performance = 2.5 TF

(2048 nodes = 4096 procs)

JRA4 : Radiation Therapy planning (joint application with EGEE)

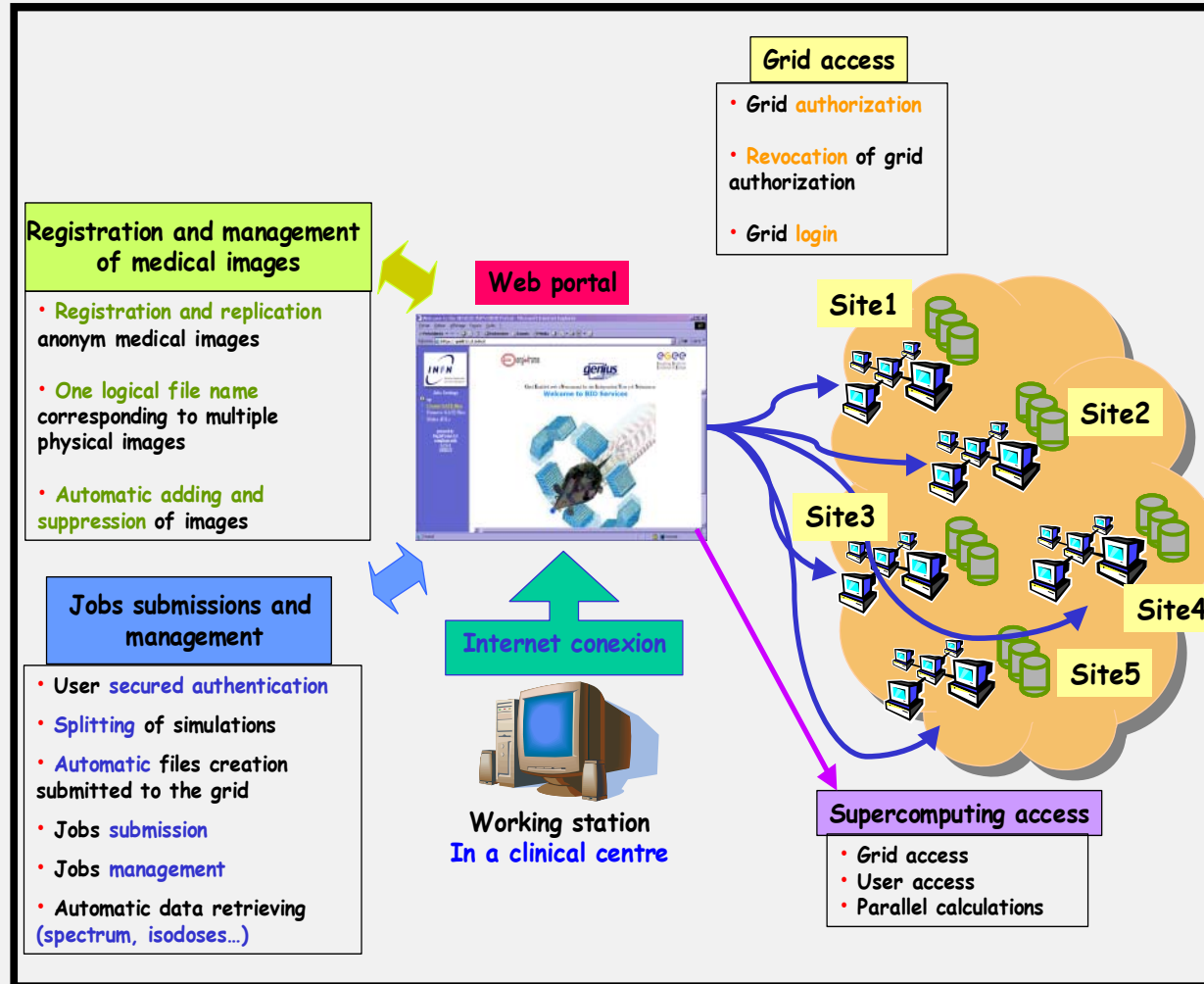

JRA5: Industrial CFD and CAA app.

Objectives:

- Demonstrate the use of commercial CFD and CAA codes on the DEISA infrastructure
- Exploit DEISA capabilities for the use of commercial codes:
 - code optimisation
 - licensing issues
 - advanced scheduling integration
- Raise the limit of industrial simulations capabilities a step forward:
 - increase the complexity of simulations
 - increase of engineering relevance of simulations
 - constraint: time to get results
- Understand how to set up commercial codes ASP service into the DEISA infrastructure

JRA5: Aerodynamic shape optimization

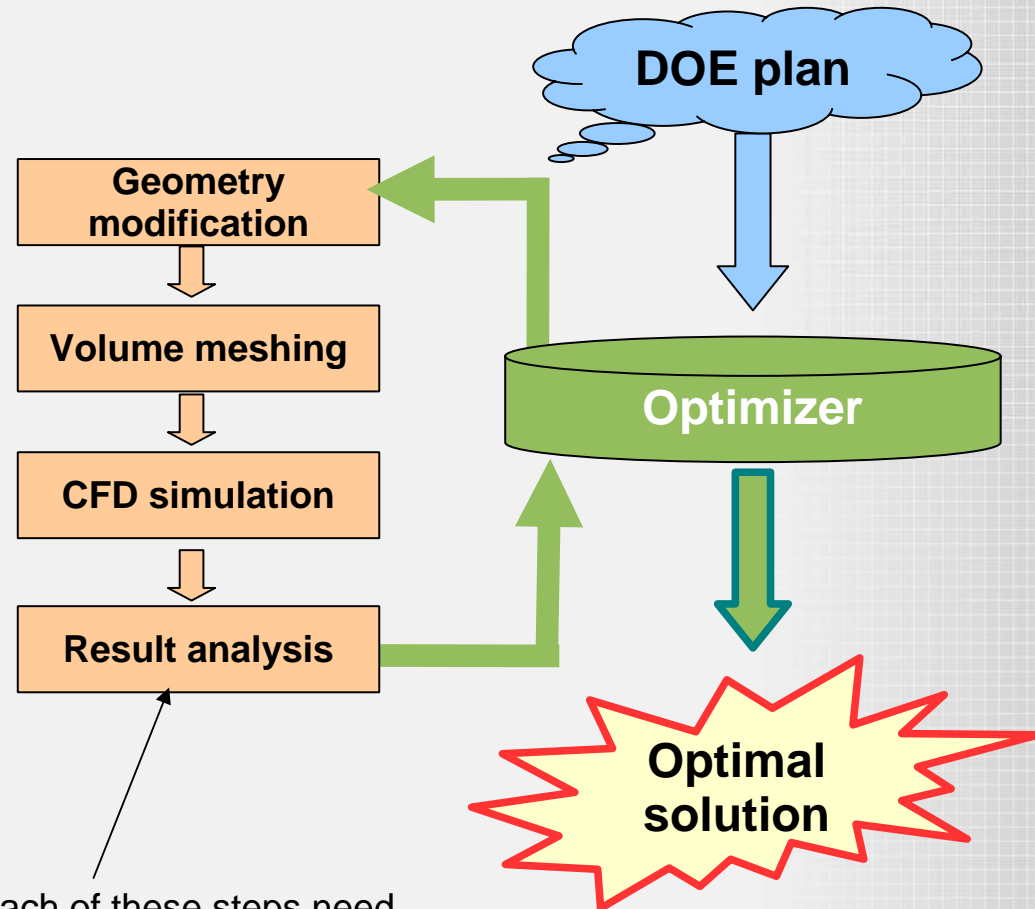
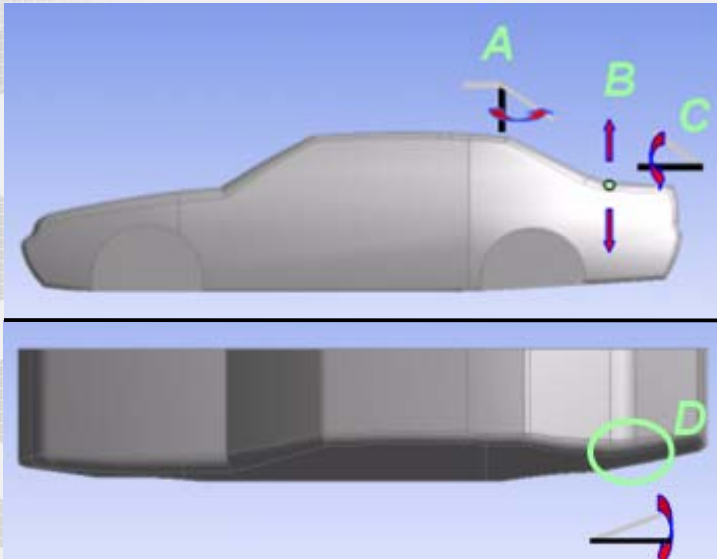

- 4 parameters to be optimized
- cubic face centered DOE
- 25 cases+16 extra cases for error estim.
- polynomial response function
- 70 hours wall clock time on 64 cpus

Each of these steps need to be fully automated and controlled by the optimizer

JRA6 : Coupled applications overview

- **Objectives**
 - To adapt coupling projects to the DEISA infrastructure and to improve the parallelism:
 - at the code level
 - at the coupling level (asynchronous models)
 - To submit coupling projects to the DECI
- **The initial projects (PM 1 - PM 18)**
 - 3 projects running today on heterogeneous platforms
- **The second set of projects (PM 19 – PM 36)**
 - Chosen among HLRS and IDRIS projects.

Initial projects (1)

- **Environmental project:**
 - Study the impact of water cycles of the hydrological and vegetation models on climate models
 - Coupling area in West Africa
 - Best performances with a vector and scalar platform
 - Improve extensibility of the architecture and the coupling part
 - AMMA project, PhD thesis, 2 publications and 2 communications

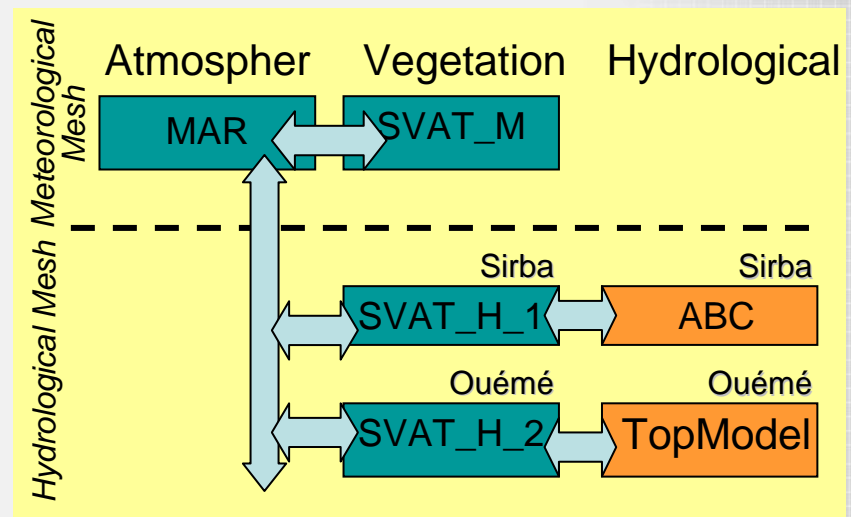
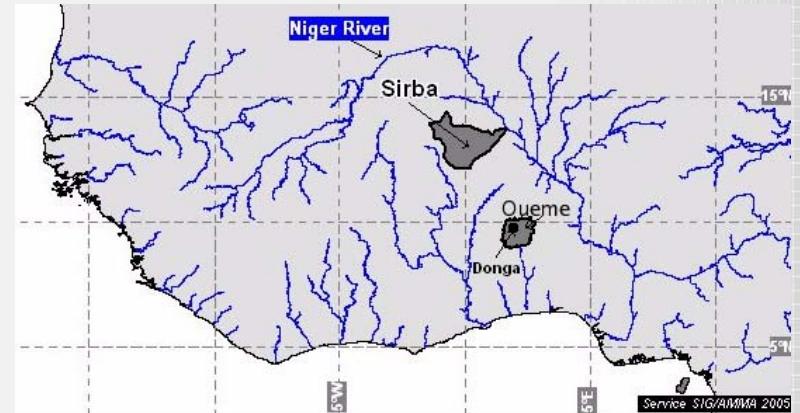

Initial projects (2)

- **Cosmological project:**
 - Study galaxy formation in cosmology
 - Physics / module: Gravitation, Hydrodynamics, Chemistry
 - Best performance on heterogeneous platforms
 - Load balancing issue and improvement of the coupling part
 - Proposed to DECI
 - HORIZON project, 1 publication, 2 communications

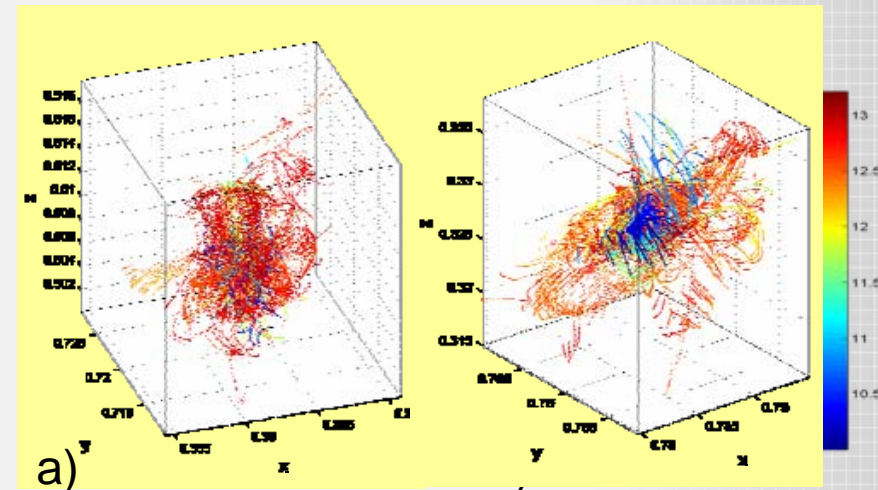
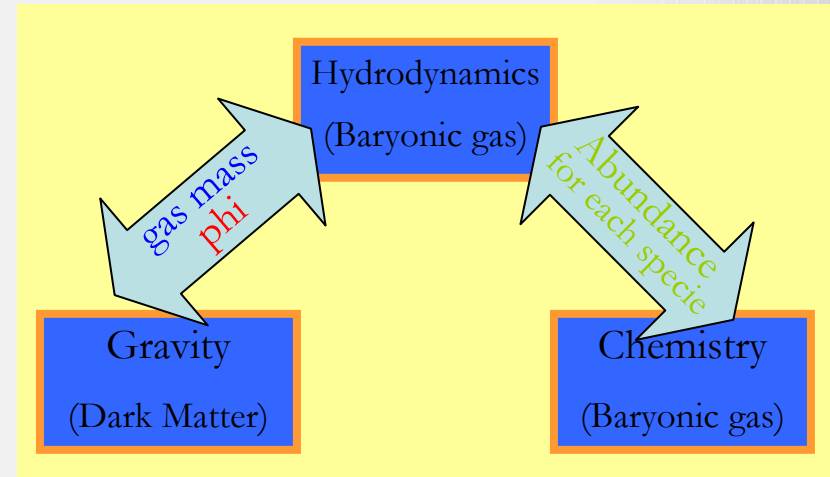

Initial projects (3)

- **Combustion / Radiation project**

- Study the impact of radiative heat transfer (RHT) on the combustion process (2D)
- Couple combustion (AVBP), the RHT (Rayon) codes and the pollutant formation (AVBP)
- Parallelization of the Rayon code and improvement of the coupling part
- Load balancing issue
- 3D extension proposed to DECI and accepted
- PhD thesis, 2 communications in international congresses

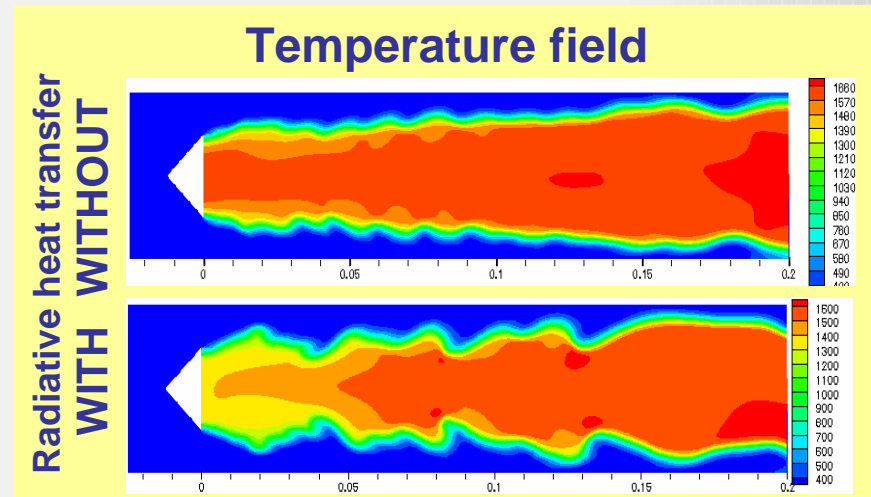
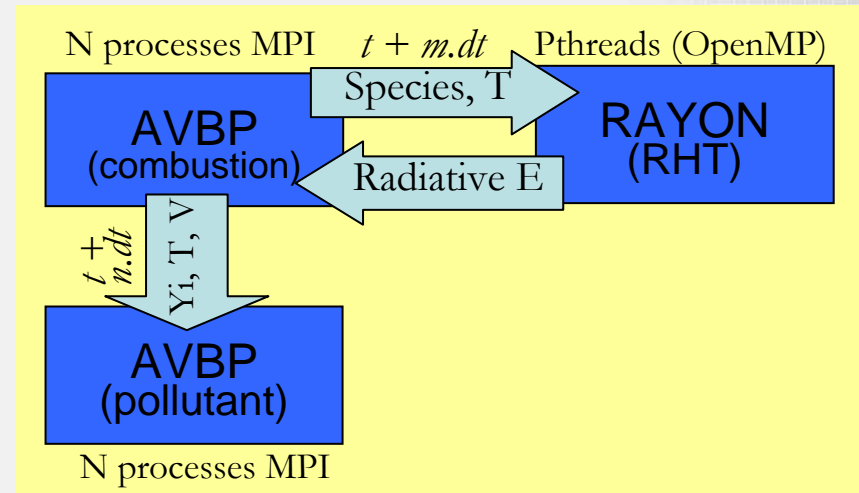

6b - DECI: enabling leading computational science

- The basic service providing model for scientific users is the **Extreme Computing Initiative** (see www.deisa.org)
- Identification, deployment and operation of a number of « flagship » applications requiring the infrastructure services, in selected areas of science and technology.
- European Call for proposals in May-June every year. Applications are selected on the basis of scientific excellence, innovation potential and relevance criteria, with the collaboration of the HPC national evaluation committees.
- There are 23 projects in operation in 2007, and 29 projects operated in 2006 (see www.deisa.org)
- Supported by the **Applications Task Force (ATASKF)**, whose objective is to enable and deploy the Extreme Computing applications. The activities of the ATASKF are focused on:
 - Hyperscaling of huge parallel applications, data oriented applications
 - Workflows and coupled applications
 - **Production of an European Benchmark Suite for HPC systems** (in collaboration with the HPC-EUR initiative, to be used in future procurements of European supercomputers).

6b - DECI status, June 2006

Acronym	Scientific Discipline	Principal Investigator(s) and Affiliation	cpu-h	Tot mem	Status	Home site	Exec Site
SIMU-LU	Computational Cosmology	Gustavo Yepes, Universidad Autónoma de Madrid, Spain	1 500 000		P	BSC	BSC
LFI-sim	Cosmology, Space Missions	Fabio Pasian, INAF – O.A. Trieste, Italy	500 000		1/4	CIN	Core
HORIZON	Astrophysics, Cosmology	Julien Devriendt, Centre de Recherche Astronomique de Lyon, France	1 400 000		P	IDR	
STARS	Astrophysical Fluid Dynamics, Stellar MDT	Allan Sacha Brun, CEA – CNRS – Univ. Paris 7, UMR7158, France	220 000		1/4	IDR	RZG
FEARLESS	Astrophysics	Jens Niemeyer, University of Würzburg, Germany	300 000		1/2	LRZ	SARA
GIMIC	Astrophysics, Cosmology	VIRGO Consortium via Simon White, Max Planck Institute for Astrophysics, Germany, and Carlos Frenk, University of Durham, UK	600 000		P	EPCC	EPCC
SUPERNOVA	Astrophysics, Supernova Research	Wolfgang Hillebrandt, Max Planck Institute for Astrophysics, Germany	240 000		F	RZG	EPCC
REIONIZATION	Astronomy	Garrett Mellema, Astron, The Netherlands	300 000		P	SARA	
TASEC	Bioinformatics	Modesto Orozco, INB, Spain	1 400 000		P	BSC	
BET	Computational Biophysics	Paolo Carloni, SISSA Trieste, Italy	200 000		F	CIN	IDRIS
SNARE	Computational Chemistry, Biology	Marc Baaden, UPR9080 CNRS, Labo. De Biochimie Theorique, France	256 000		P	IDR	RZG
LCDIS	Physical Chemistry of Materials	Claudio Zannoni, Universita' di Bologna, Italy	200 000		P	CIN	
NATURE	Nanoscience, Materials Science	Risto Nieminen, Helsinki University of Technology, Finland	1 000 000		P	CSC	
LIAMS	Large Scale Molecular Dynamics	Peter V. Coveney, University College London, UK	600 000		P	EPCC	Core
IQCS	Quantum Computing	Hans de Raedt, University of Groningen, The Netherlands	100 000		P		
CAMP	Materials Science	Michele Parrinello, ETH Zurich, Switzerland	300 000		1/2	RZG	FZJ
POLYRES	Materials Science	Kurt Kremer, Max Planck Institute for Polymer Research, Germany	350 000		1/2	RZG	CIN
QCfarm	Quantum Chemistry	J.H. van Lenthe, Utrecht University, The Netherlands	1 000 000		P	FZJ	
Channel-2000	Fluid Mechanics	Javier Jiménez, Universidad Politécnica de Madrid, Spain	819200		F	BSC	BSC
HEAVY	Turbulence, Fluid Dynamics	Federico Toschi Istituto per le Applicazioni del Calcolo – CNR, Italy	400 000		P	CIN	
FOCUS	Combustion	Olivier Gicquel, Ecole Centrale Paris – CNRS / France	300 000		P	IDR	
SUN	Computational Fluid Dynamics	Jörn Sesterhenn, Technical University of Munich, Germany	300 000		P	LRZ	
GLORIA	Earth Science – Air Quality and Climate Change	José M. Baldasano, Barcelona Supercomputing Center (BSC-CNS) - Earth Science Division, Spain	450 000		P	BSC	
SSSC	Earth System Modelling - Atmospheres	Heikki Järvinen, Finnish Meteorological Institute, Finland	300 000		P	CSC	
ESSENCE	Climate Research	H.A. Dijkstra, IMAU, Utrecht University, The Netherlands	1 200 000		P	SARA	HLRS
GROM	Physical Oceanography	Pierre Bahurel, GIP Mercator Océan, France	450 000		P	IDR/ ECMWF	ECMWF
GYROKINETICS	Plasma Physics	Karl Lackner, Max Planck Institute of Plasma Physics, Germany	500 000		P	RZG	LRZ
HDM	Particle Physics, Nuclear Physics	Kari Rummukainen, University of Oulu, Finland	350 000		1/4	CSC	
TMQCD	Lattice Field Theories	Karl Jansen, DESY-Zeuthen, Germany	350 000		1/2	FZJ	Core

6c - The Life Sciences Portal

- The objective is to extending the outreach of the supercomputing infrastructure by reaching new users communities that have already structured their applications strategies around small discipline oriented grid infrastructures with discipline specific tools.
- The strategy is to connect supercomputer environments as « backend » resources to existing discipline oriented elnfrastructures.
- Community allocations will enable the access of external anonymous users.
- To move in this direction, DEISA plans to deploy in 2006-2007a portal to a European supercomputing service for bio-informatics and Life Sciences. This is a discipline in which the need of HPC is strongly emerging in some domains.
 - Critical domain applications are ported to the most adapted supercomputer of the DEISA environment
 - Shared data repositories are hosted by GPFS services
 - A DEISA portal will be deployed, but interoperability with existing portals will be searched
- **This ASP (Application Service Provider) model is potentially well adapted to external corporate users.**

6d - Collaboration with other projects

- **DEISA and EGEE have complementary objectives and strategies. Close collaboration is mandatory. Planned joint meetings to decide on cooperation strategy. The main interest is in applications that require access to both infrastructures.**
- **TeraGrid and DEISA have common visions on the deployment and operation of supercomputing Grids.**
- **Main subjects of TG-DEISA collaboration: GPFS, INCA (the software monitoring tool for the CPE), stripped GridFTP.**
- **DEISA is deeply engaged in GGF's Grid Interoperability Now (GIN) initiative involving all the Major Grid Projects in the world.**

7 - Prospective issues

- DEISA is deeply concerned with three strategic issues:
 - *How should HPC be structured in Europe, to further enhance capabilities*
 - *How to move towards persistent, sustainable research infrastructures*
 - *How to make of DEISA non exclusive but efficient organization.*

How should a global HPC infrastructure in Europe look like?

- Emerging consensus about a global, strongly coupled infrastructure « à la DEISA » integrating the current national terascale systems (Tier 2) with new generation petascale systems (Tier 1) into a unique service providing environment, with a unique operational model.
- **T1 should provide exceptional capability computational resources**, with a significant performance difference with respect to T2. We expect at any time a small number of T1 systems.
- T1 systems will be shared and European.
- A basic requirement is **cooperative operation of T1 and T2** including high performance access to existing national data repositories. This is why the data management services that DEISA is deploying are highly relevant.
- Exceptional resources will be concentrated in a very limited number of sites, but **services, know how, competence and leadership should remain distributed.**

T1 – T2 infrastructure

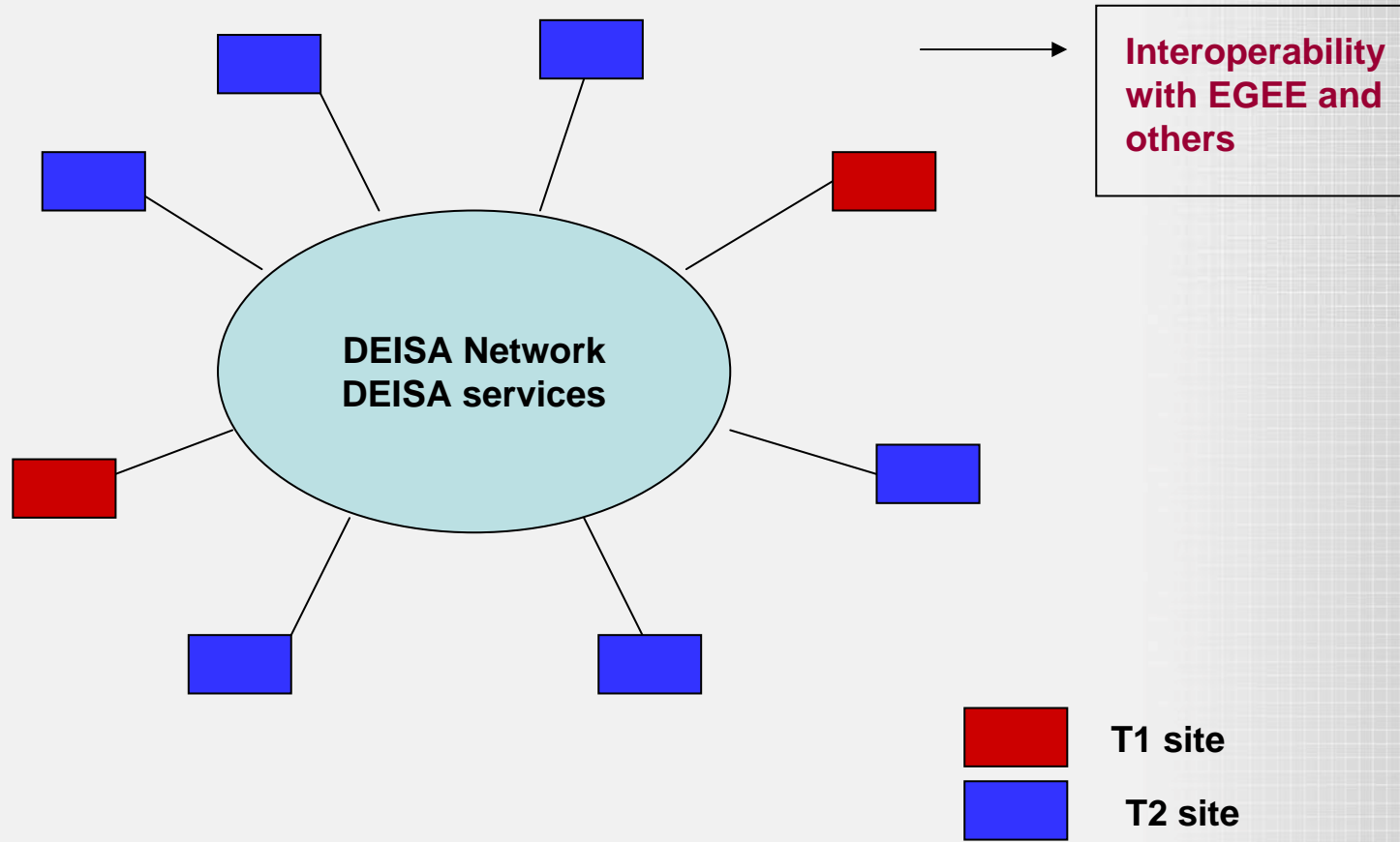

HPC Ecosystem: option A

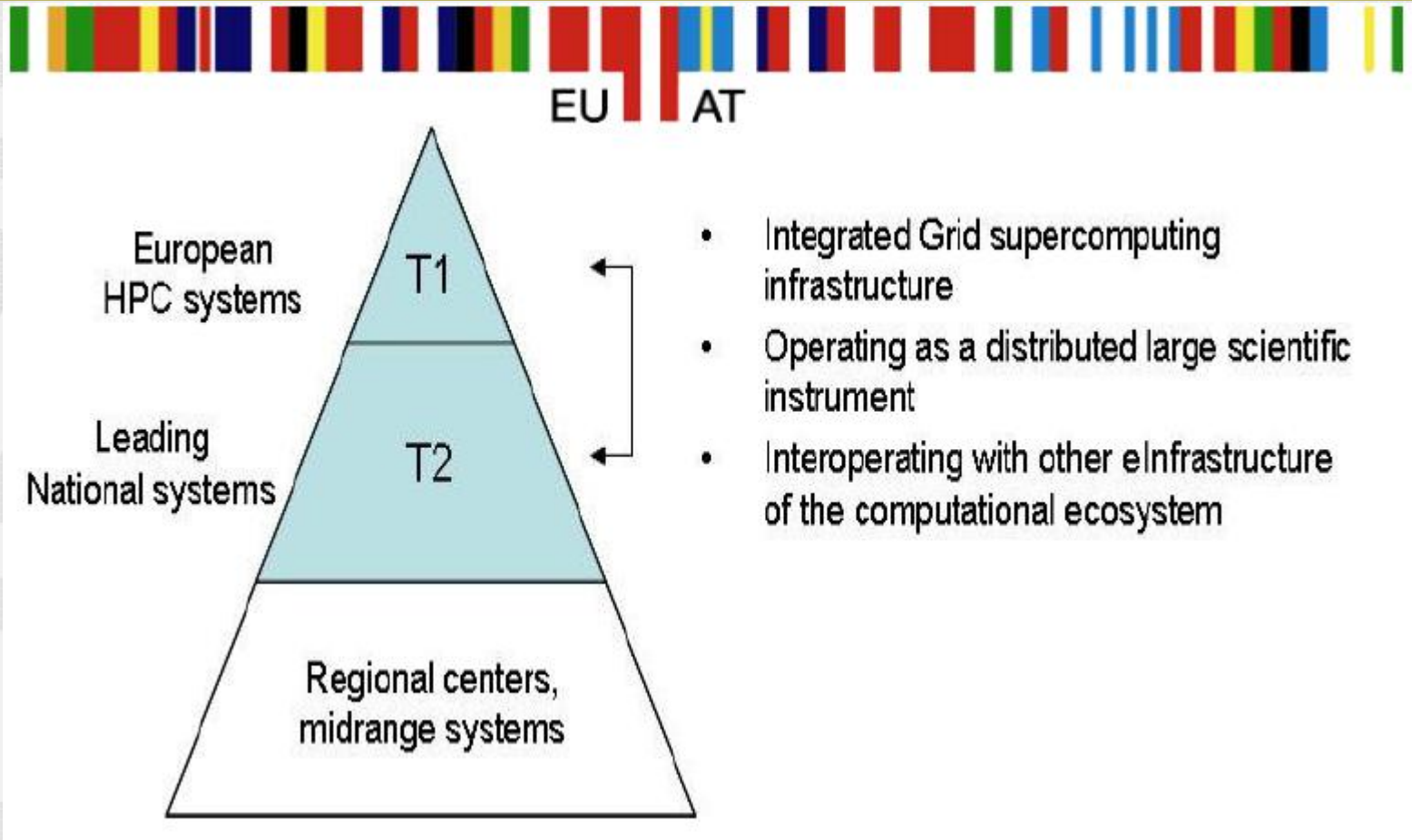

8 - Conclusions

- DEISA aims at deploying a **sustained and persistent**, basic European infrastructure for general purpose high performance computing.
- **We expect services and existing synergies to be persistent.** We do not claim persistency of the current organizational model. The DEISA Consortium has defined clear new FP7 strategies and is establish a roadmap incorporating cooperation or integration with new HPC initiatives.
- Our next challenge is **establishing an efficient organization embracing all relevant HPC organizations in Europe.**
- Interfaced with the other grid-enabled complementary infrastructures, DEISA expects to continue to contribute to a global European infrastructure for science and technology
- *Integrating leading supercomputing platforms with Grid technologies and reinforcing capability with shared petascale systems is needed to open the way to new research dimensions in Europe.*