Decomposition Strategies

.



- Decomposition patterns
 - Domain decomposition
 - One Stage and two stage optimization
 - Irregular decompositions
- Data replication
- Underpopulation
- I/O
 - SMP cluster optimized
 - Asynchronous
 - MPI-IO

- Parallel codes require data to be distributed
 - Regular or irregular data distribution
 - Data replication
- Decomposition of data across processors impacts performance
 - Data distribution affects communication patterns
 - Looking to maximise computation to communication ratio
- SMP clusters introduce level of non-uniformity to the decomposition problem
- Decomposition maybe dependent on the data set

- **Mapping N dimensional dataset over processors**
 - Must match processor groups (nodes) to sections of the data
 - Exploit fast "on-node" communications
 - Reducing impact of message latency
- **Simplest optimization is to map dimensions to nodes**
 - Removes a direction of "off-node" communications for each dimension mapped
 - 2D dataset: decompose one dimension across nodes, and fit one into the nodes
 - 3D dataset: match 2 dimensions to the node size, removing two directions of communications
- **3D decomposition slicing**
 - Allows more regular decompositions

- Performance benefit dependent on communication pattern
 - Regular boundary swapping communications ideal
- May not be practical for many datasets
 - "Square" datasets could produce decompositions with poor surface area to volume ratios
- Depends on node sizes and number of nodes used

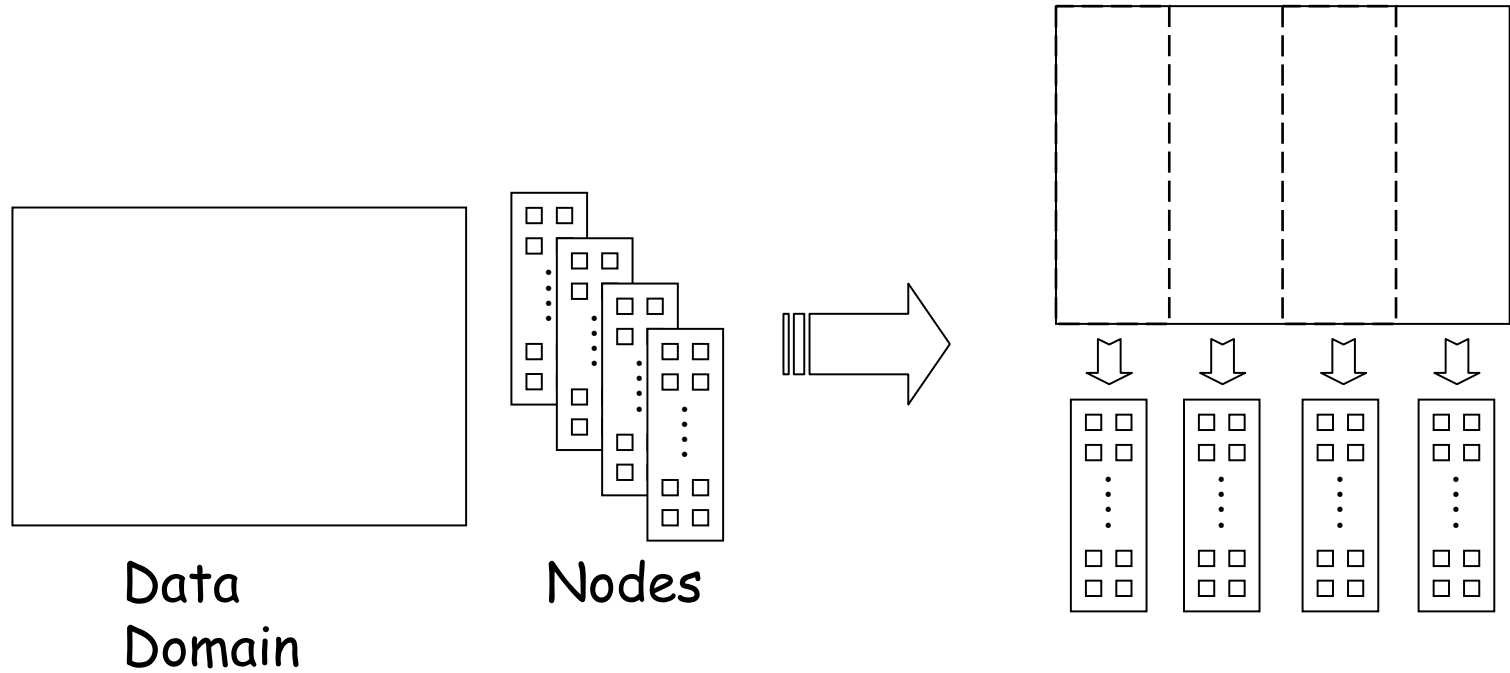

- Require a strategy for data decomposition within a node
- Simplest mechanism is to use a 1D decomposition within a node
 - Simple to program and understand
- Regular communication pattern can cause load-balance problems using simple strategy
 - Communications non-uniform latency and bandwidth

Two stage decomposition

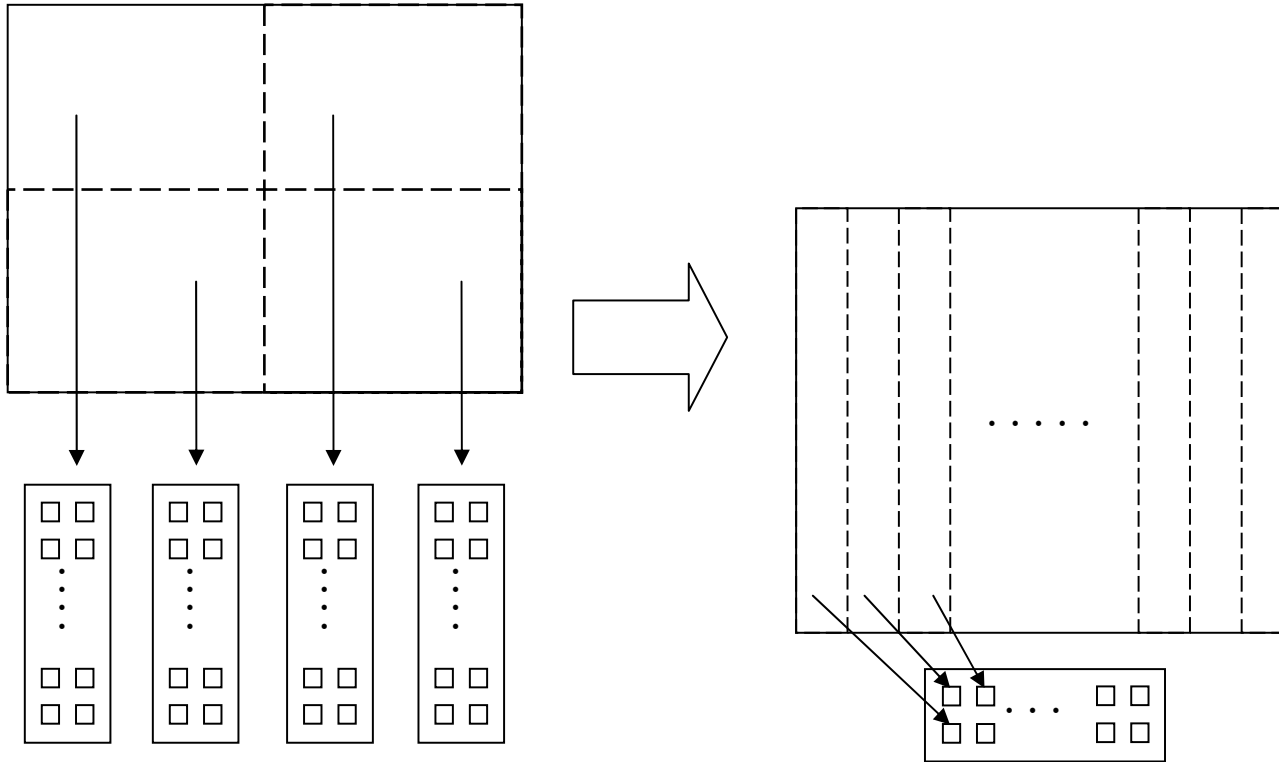

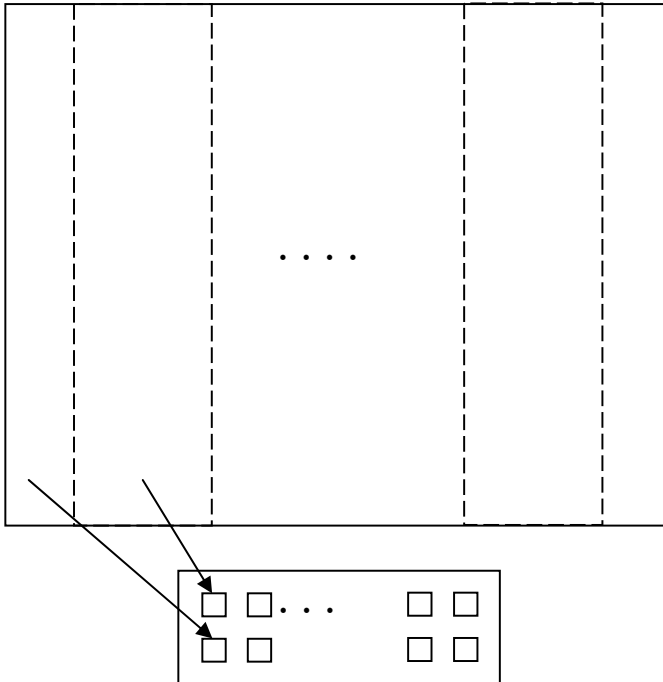

- Decompose data over nodes in a balanced fashion
- Use a non-uniform pattern within a node to ensure load balance
- 1D decomposition can be altered to take into account communication load

- Further optimization - isolate the off-node communication load to the fewest possible processors
- Using a 2D decomposition, data that relies on off-node processes can be allocated to one processor
- "Internal" processes have a larger computation load

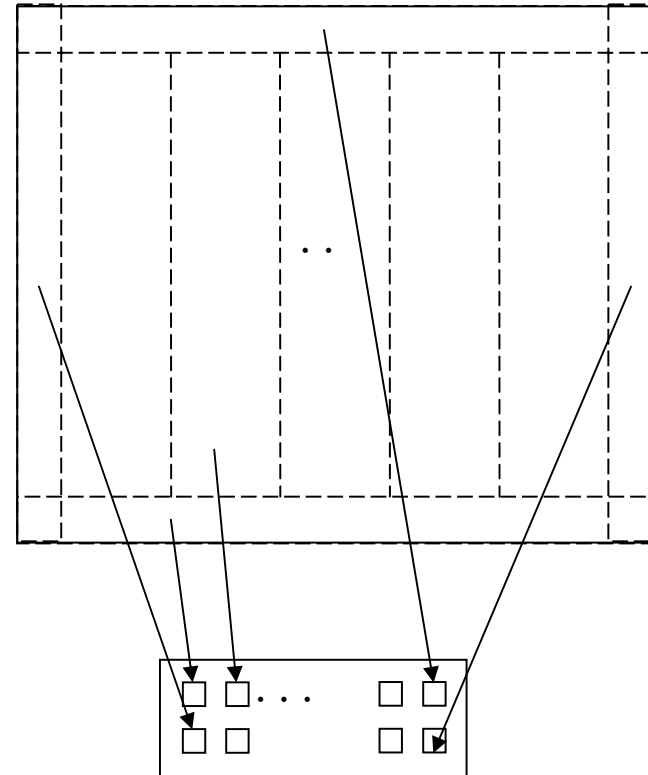

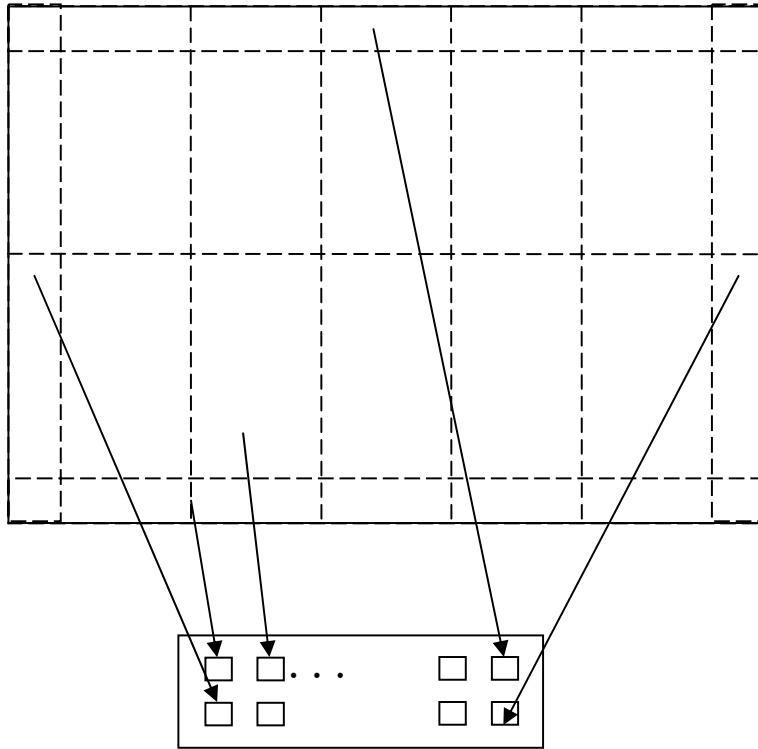

- More practical but greater latency
- Overlapping communications necessary to gain benefit
 - Non-blocking MPI: IRecv, ISend, Wait

- Same algorithm with different datasets may need different decompositions
 - May need to experiment to get optimum decomposition
 - Self-tuning may be an a helpful tool
- Interaction between across-node decomposition and on-node decomposition

- May optimize performance where data is stored locally or resources attached locally
- Good for irregular decomposition
- By default many systems number linearly
 - This means that communication patterns may not be optimized
- By creating a cartesian communicator we may achieve an optimized communication pattern
 - By setting `Reorder=True`
 - However some systems may not do something sensible

- Graph-optimization based decomposition can be optimized for SMP clusters
- Mapping elements to nodes is key
- Basic decomposition involves computing a graph that minimises the number of links between elements to reduce computation
- Also attempting to load-balance the number of elements per processor

- For SMP clusters, the graph optimization algorithm should take into account two levels of links
 - Slow "off-node" links, and fast "on-node" links
 - Optimize to reduce number of slow links between large groups of elements connected by fast links
- This allows for off-node and on-node communication to be load-balance again each other
- Must also distributing work within nodes

- Simplest way to optimize for cluster is to perform the decomposition twice

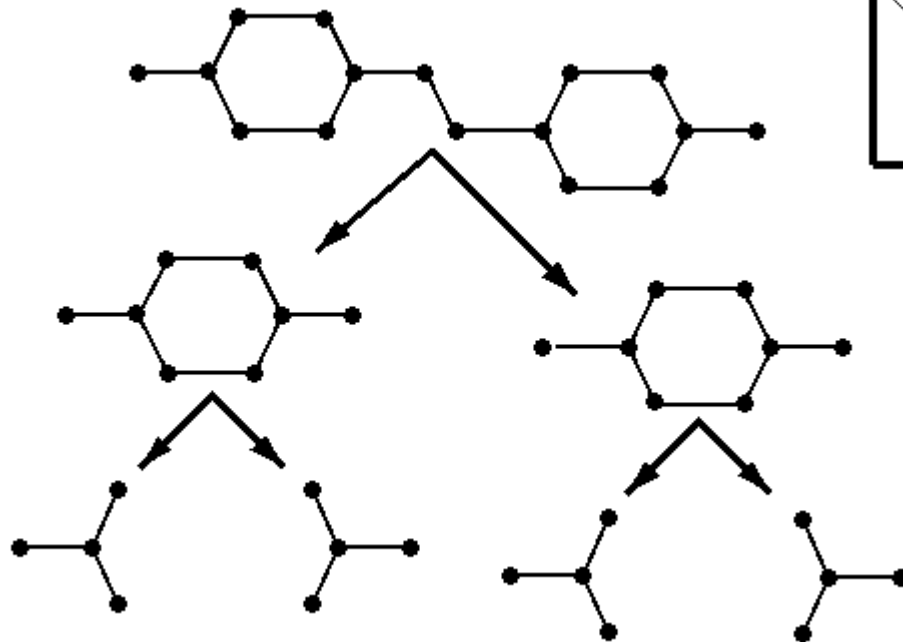
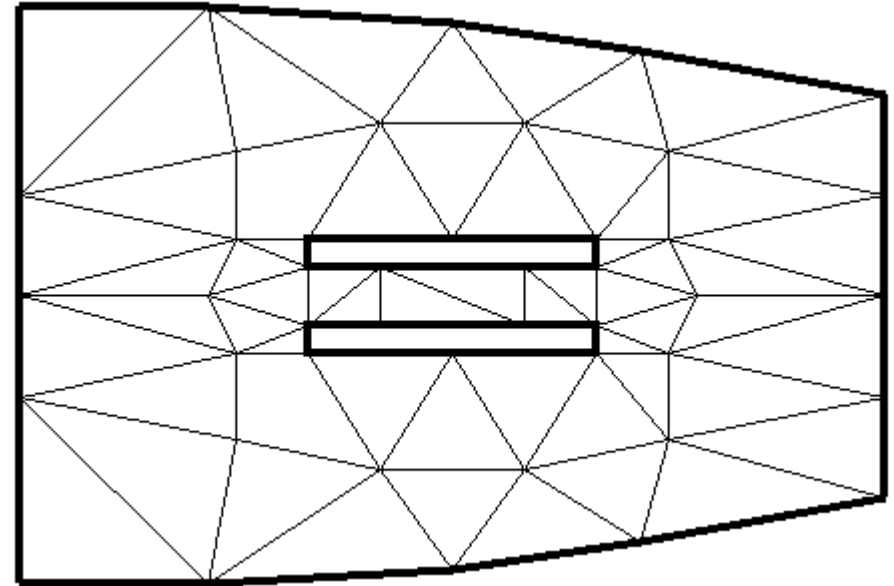

- Run same algorithm in two stages to give:
 - 1st Global decomposition
 - 2nd Local decomposition

- Replicated data problems can also be optimized for clusters:
 - One copy of data shared per node
- Dramatically reduces memory used
 - For 32 processor nodes, consuming a $1/32^{\text{th}}$ of memory
 - Can allow much larger problems to be computed
- Can be costly to computation
 - Memory bandwidth to shared array can restrict performance
 - Maybe synchronisation issues when updating shared memory

- Performance improvement can be achieved with under populated nodes
 - E.g. for the AMBER* code on an IBM p690:

8 procs (1 node, 8 procs per node)	247s
8 procs (2 nodes, 4 procs per node)	259s
16 procs (2 nodes, 8 procs per node)	191s
16 procs (4 nodes, 4 procs per node)	170s
32 procs (4 nodes, 8 procs per node)	171s
32 procs (8 nodes, 4 procs per node)	133s
64 procs (8 nodes, 8 procs per node)	162s
64 procs (16 nodes, 4 procs per node)	139s

- For some parallel codes
 - IO can be a time consuming bottleneck
- IO installations on SMP clusters vary widely
 - Highly customised
 - IO system on SMP clusters can be SMP clusters themselves
- Speed vs Usability and Portability
- Reading and Writing may need different strategies

- Two main I/O setups
 - Global File System
 - Local File System
- Key difference is the level at which communication occur
 - O/S level -> Global File System
 - Software level -> Local File System
- Performance depends on Interconnect
 - Special purpose: GPFS,
 - General: NFS, Ethernet, ...
- Usability and scalability dependent on configuration

- Single processor master IO is a common approach

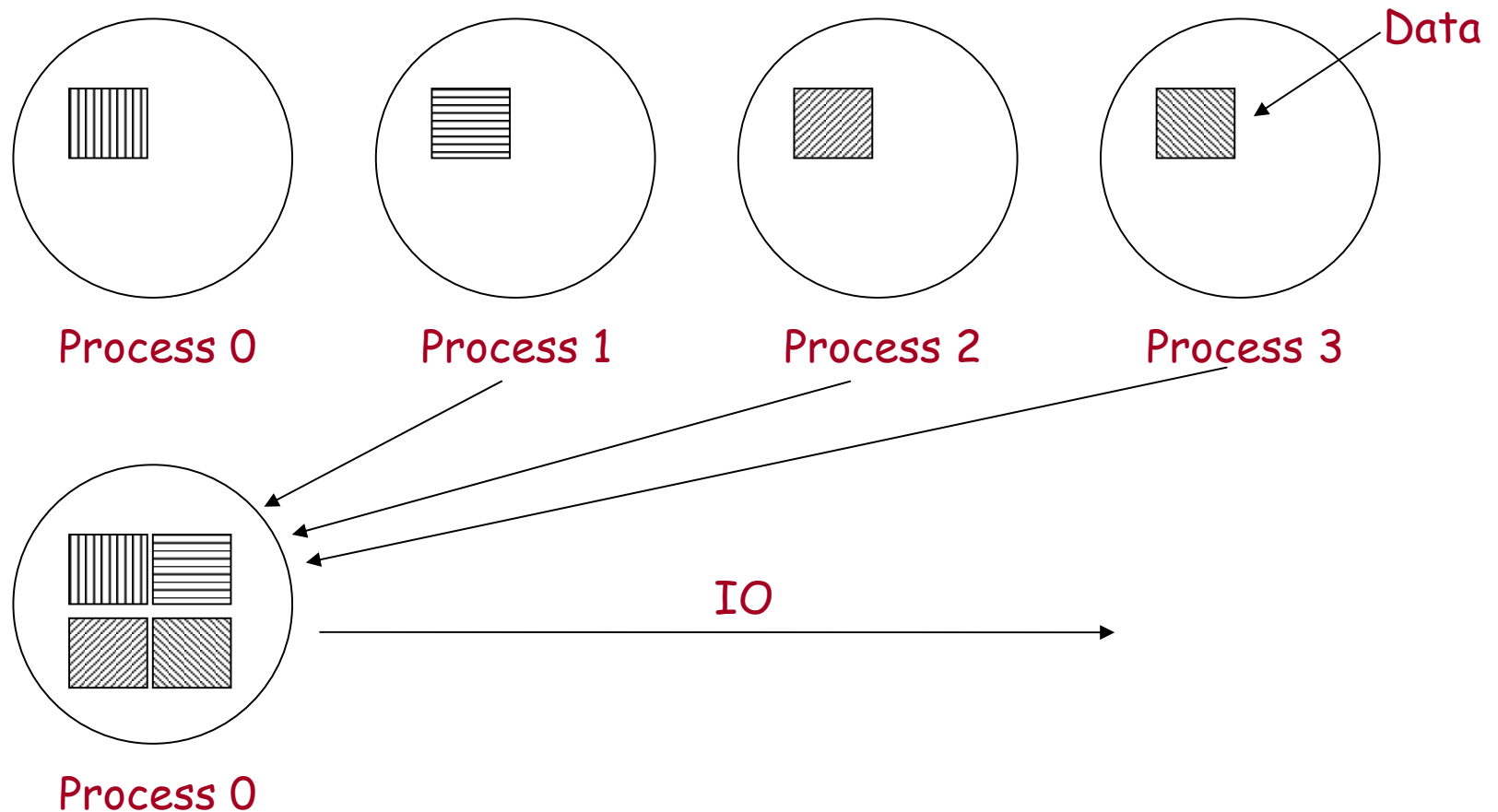

- Single processor I/O master approach can severely limit large processor jobs
 - Involves two stage communication process
 - Heavy use of the network
 - Master node is doing a large amount of work - load imbalance
 - Master node may run out of memory

- Each processor can write to its own file, removing one communication stage
 - Local I/O caching, less contention for switch and memory bandwidth
 - Pre/post-processing of files required
 - Checkpointing and restarting on a different number of processors may not work

- An optimized clustered Master I/O approach is possible
- One master process per node gathers /scatters data and performs the I/O
 - Reduced synchronisation as only "fast" communications used
 - Improved usability as only a small number of files needed
- Gather/scatter performed either using MPI communications or a shared-memory segment
- May need to use a small group of processors per node to get improved performance

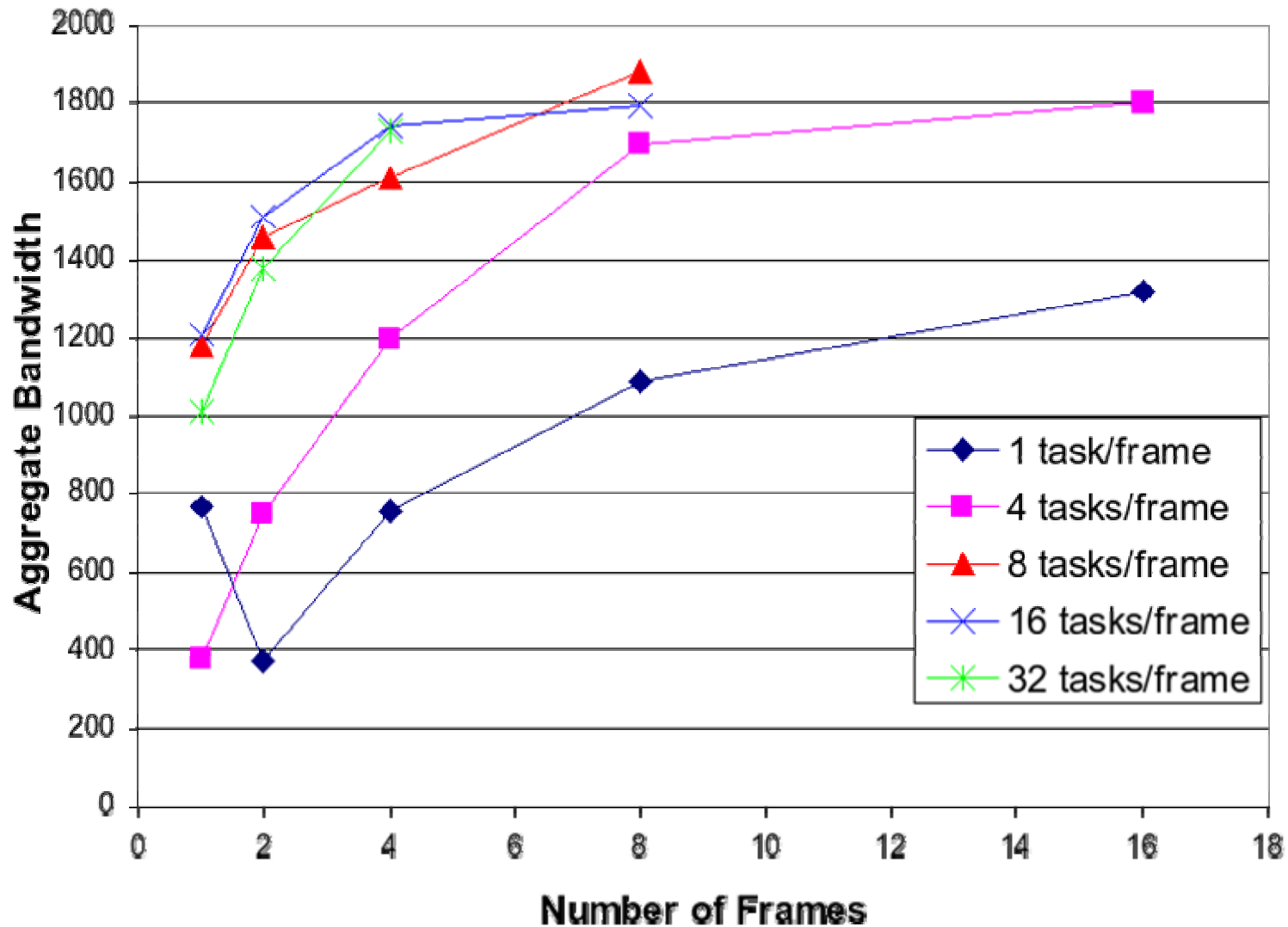

- Each process reads and writes to the same file
 - Use "random access" file to write or read from different positions in one file
 - Removes large number of files, improves usability
- Can complicate programming and dependent on hardware setup
 - Less portable than using separate files
 - May not be able to make full use of I/O system performance
- Requires knowledge of number of processor and data decomposition used
 - Robust code should handle different datasets

- Writing or reading large amounts of data can be optimized using Asynchronous I/O (i.e. non-blocking)
 - When the I/O function is called, the function finishes immediately, allowing the program to continue
- Asynchronous I/O may still impact computation / communication performance as it's using system resources
 - May spawn threads that will cause context switch
- Again, dependent on hardware setup and OS implementation
 - Reduces portability

- MPI library provides Parallel I/O functionality (MPI-2)
 - Simple, portable access to files
 - Portability depends on MPI implementation
- Allows the reading of a single file without worrying about how many processors created it
 - Achieve decomposition-independent file formats for 2 and 3D data or processor distributions
- Greater portability than machine specific I/O
- Greater performance than master serial I/O
- Often optimized for large datasets and file sizes, and large numbers of processors

- Data decomposition and communication patterns can significantly impact performance for large numbers of processors
 - Aim to reduce synchronisation costs and maximise load-balance
- Any decomposition pattern must take the different communication performance into account
 - Two levels of communication cost
 - Non-blocking communications essential to mask latency
- I/O load can be reduced depending upon your requirements

- *AMBER Performance on HPCx, L. Smith, C. Johnson, HPCx Technical Report, 2003. See: <http://www.hpcx.ac.uk/research/hpc/>*
- *File I/O from multi processor jobs, Joachim Hein, HPCx Technical Report, 2003. See: <http://www.hpcx.ac.uk/research/hpc/>*